

NON – RETURN - VALVE

- flow optimized discharge chamber
- reduced voidage
- compact design
- different nominal widths can be combined

RSK 63

Specifications

Nominal widths:	bore diameter 63mm, external diameter 40 / 50mm
Medium:	water / sewage / pellets
Material of body:	PU-ABS
Material of seal:	EPDM/NBR/FKM
Material of axis:	Stainless Steel
Operation temperature:	- 30 to + 90°C
Installation position:	vertical and horizontal Up to 20 degrees of declination
Weight:	0,6kg

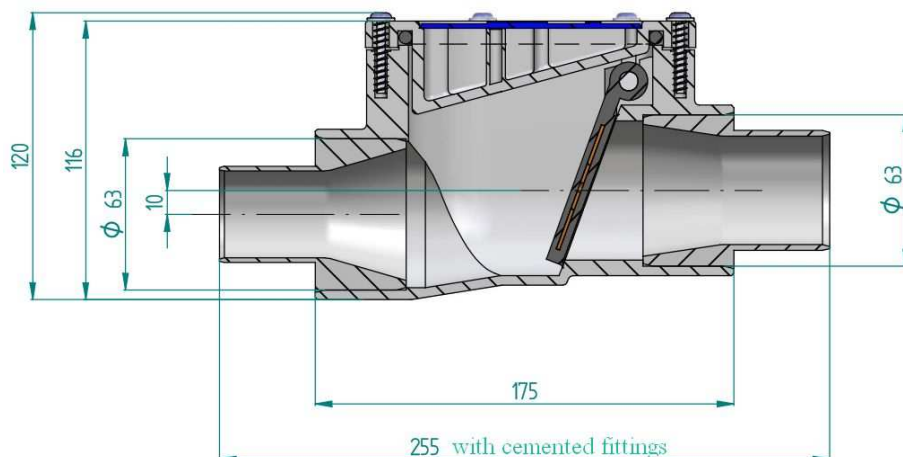

A variable usage in many areas of water- and sewage systems as by handling of pellets (also in cramped situations) is possible by a compact geometry of the body. By dimensioning the bore diameter to 63mm it is possible to cement standard tubes directly. There are reducing fittings with external diameter of 50 and 40 mm which enables a various connecting capability.

- Errors and engineering change excepted -